

ISIMET

E – Series Enclosure Custom Assemblies

Installation, Maintenance and Operation Instructions

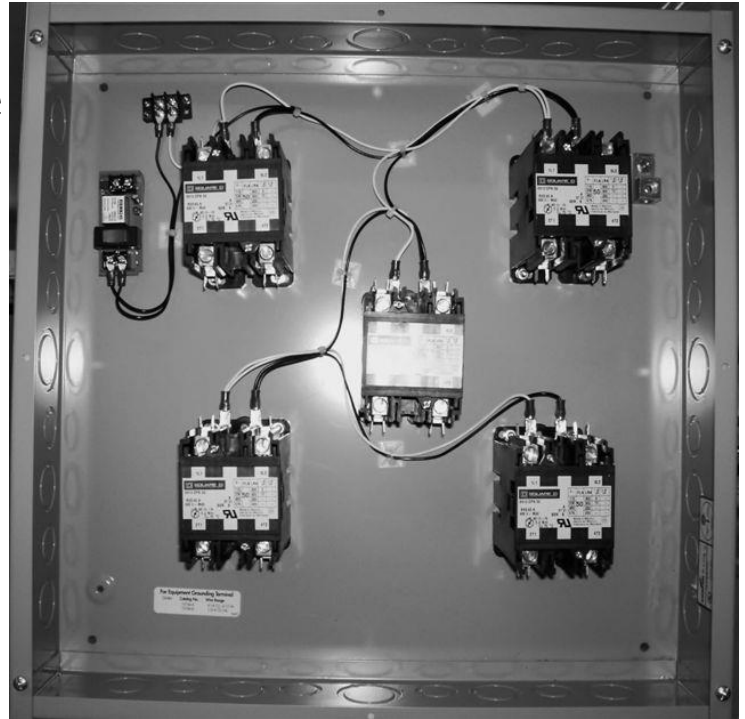

The Custom Assembled E-Series Enclosures is pre-assembled and pre-wired enclosure intended for use with the ***ISIMET*** Utility Controller where current load demands exceed the typical 20 amp circuits typically operated by the standard E-Series. The Enclosure utilizes a Square D Definite Purpose Relays with 120 vac coils operated by 24 vac control relays.

Table of Contents:

	<u>Page</u>
Warranty.....	2
Enclosure Specifications	3
Relay Specifications.....	3
Model Number.....	4
Enclosure Dimensions.....	4
Wiring Information and Instructions.....	5
Wiring Diagrams.....	5
Installing the Enclosure.....	6
Installing the Door Panel.....	7
Installing the Door Trim.....	7

ISIMET

E – Series Enclosure: Custom Assembly
Installation, Maintenance, and Operations Instructions

Copyright © 2015 **ISIMET/MAPA, LLC**.
All rights reserved.

This document is copyrighted. This document may not, in whole or part, be copied, duplicated, reprinted, translated, electronically stored, or reduced to machine readable form without prior written consent of **ISIMET**.

Although the material contained herein has been carefully reviewed, **ISIMET** does not warrant it to be free of errors or omissions. **ISIMET** reserves the right to make corrections, updates, revisions, or changes to the information contained herein.

ISIMET is a trademark of **ISIMET/MAPA, LLC**, an affiliate of **WCM Industries, Inc.**

Warranty:

ISIMET will repair or replace any defective parts or workmanship of the product for a period of one year from date of installation. Damage caused by incorrect installation or improper usage is not warranted. Failure to follow recommended installation, operation, and/or maintenance procedures may void product warranty. Recovery rights shall be limited to the total sum of the amounts paid for the product by the purchaser.

Limits of Liability:

ISIMET's liability shall be limited to costs of repair or replacement parts. The Laboratory Service Panel and Utility Controller Systems are not intended for usage other than those expressly described in the provided manuals for each product. **ISIMET** shall not be liable for damage or injury caused by the improper use of the product.

ISIMET does not warrant against or assume liability for failure of operation or lack of notification to secondary integrated monitoring systems. The system should be thoroughly tested and adjustments made at time of initial operation. Periodic testing should be conducted by the user to assure that all components function and operate according to specifications.

Care should be taken in the installation of this product. **ISIMET** shall not be liable for damage or injury caused from the improper installation of the product.

Warranty is Subject to Compliance with Specific Installation Requirements.

EXTENDED WARRANTY:

ISIMET will extend the warranty period of the products when installation complies with all start up procedures and that a factory authorized agent either performs or is in attendance during start-up of the system(s). Controllers, Companion and Accessory Panels will be extended to a period of five years from date of installation. Except for **ISIMET** FLA, DLA, RLA and other Units where automation systems are not common, Control System(s) must be interfaced with a building automation system or other **ISIMET** approved time sequencing control for “non-use” system shutdown. All operating components of the system must be **ISIMET** provided. Prescribed routine maintenance procedures must be performed per **ISIMET** recommendations.

All Start-up and Routine Maintenance Documentation shall be per Factory Recommendation.

Further, required start-up and maintenance procedures must be performed as directed upon all affected systems. This warranty shall only become enforceable upon issuance of application specific Extended Warranty Document. A copy of this document should be maintained at all times at the location of the warranted systems.

DISCLAIMER OF IMPLIED WARRANTY:

THERE ARE NO WARRANTIES THAT EXTEND BEYOND THE DESCRIPTION HEREIN. SELLER DISCLAIMS ANY IMPLIED WARRANTY OF MERCHANTABILITY OF THE GOODS OR OF THE FITNESS OF THE GOODS FOR ANY PURPOSE, AND BUYER AGREES THAT THE GOODS ARE SOLD “AS IS.”

Printed in the United States of America.

Enclosure Specifications:

The NEMA 1 enclosure may be either surface or flush mounted. Gray Powder Coat is available in surface mount only and provided with screw cover panel. Latch for White Powder Coat or Stainless hinged doors may be specified as Screw Driver Latch, Keyed Lock, or Hand Knob.

The enclosure is available in gray powder coat, or GPC with WPC door, or GPC with brushed stainless door.

Series 1 and 4 Enclosures (WPC or SS W/Gray PC Enclosure with Hinged Door)

Relays are assembled using a 16X14X6 or 18X18X6 enclosure and when specified as flush mount are provided with the *ISIMET* Trim Kit for installations in finished/occupied areas. Flush Trim adds 3.5 inches to both Height and Width Wall Surface dimensions.

Relays are arranged within the enclosure to insure ease in making field-wiring connections.

Relay Specifications:

Definite Purpose Relays – Square D Relays with 120 vac coils. Relay contacts per specific project requirements. Maximum operating temperature for the contact is 160° F / 71° C.

Average operating time in milliseconds: 15 pick-up; 16 drop-out.

Note: 24 vac Control Relays with Switch and Track are provided for each independent operating circuit.

Important!

Do not install wiring or cable for integrated systems, remote panic assemblies or other interface wiring within conduit for either 24-vac control or 120-vac line voltage. Each wiring system should be housed in independent conduit and not bundled with wiring for other systems.

All local electrical codes must be followed when installing this enclosure and making the wiring connections.

Verify that the electrical supply is disconnected prior to making the wiring connections or servicing enclosure.

Installation should not inhibit access to the circuits, relays or contacts for the purpose of routine maintenance. The Enclosure should be mounted in a position and location whereby service to the unit can be rendered readily from a step ladder through ceiling access.

Model Number Description

Model numbers are unique per the application in that the number describes the quantity of relays, number of contacts and amperage for each relay housed within the unit.

Example:

E-31-2X3/40-3X3/50-S defines a unit where two (2)-3 pole, 40 amp relays and three (3)-3 pole, 50 amp relays are provided in an enclosure with separate control relays for each and a Screw Cover Panel.

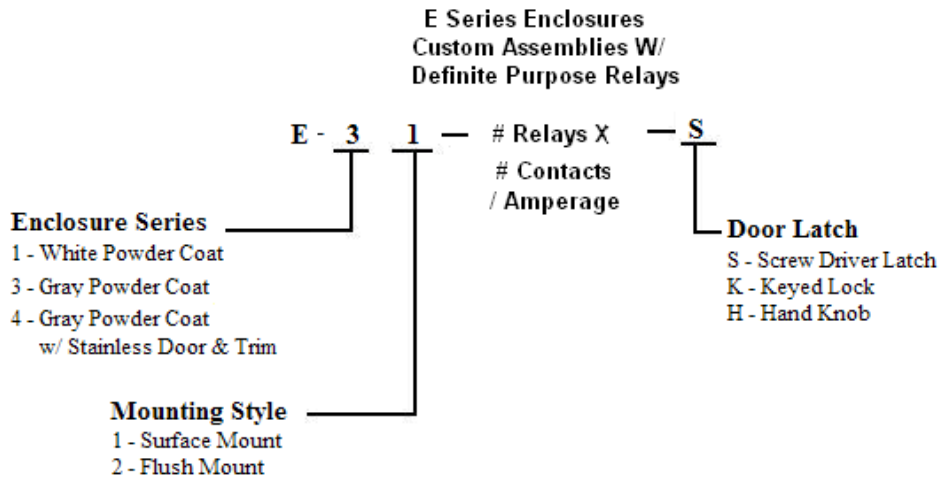

Enclosure Dimensions:

Enclosure Style	Series 3	Series 1 & 4	Series 3	Series 1 & 4
Height	16	16	18	18
Width	12	14	18	18
Depth	4	6	4	6

Series 3 units - Screw Cover Panel

Series 1 & 4 units - Hinged Door

Series 3 units are Surface Mount only.

Size of enclosure is dependent on number and amp ratings of relays provided.

Wiring Information and Instructions:

Enclosures are provided with Model # RIBMN24S panel mounted interface relay.
Contact leads from interface relay are connected to coils at each Definite Purpose Relay.
Relay is labeled to correspond with the output circuit from the Utility Controller.
Field wiring required from Load Center to a terminal within the Enclosure for continuation to the AC relay coil.
Field wiring required from Load Center to the AC relay contact.

Caution: Connect 24 VAC control wiring from Utility Controller output circuits to input terminal at interface relay.

Load Center: We recommend maximum 20-amp breaker for the coil power circuit. Other circuits are per specific project specifications and requirements. Do not exceed amp rating for relay contacts.

Grounding: Enclosure should be grounded by terminating service ground wire to enclosure at grounding lug.

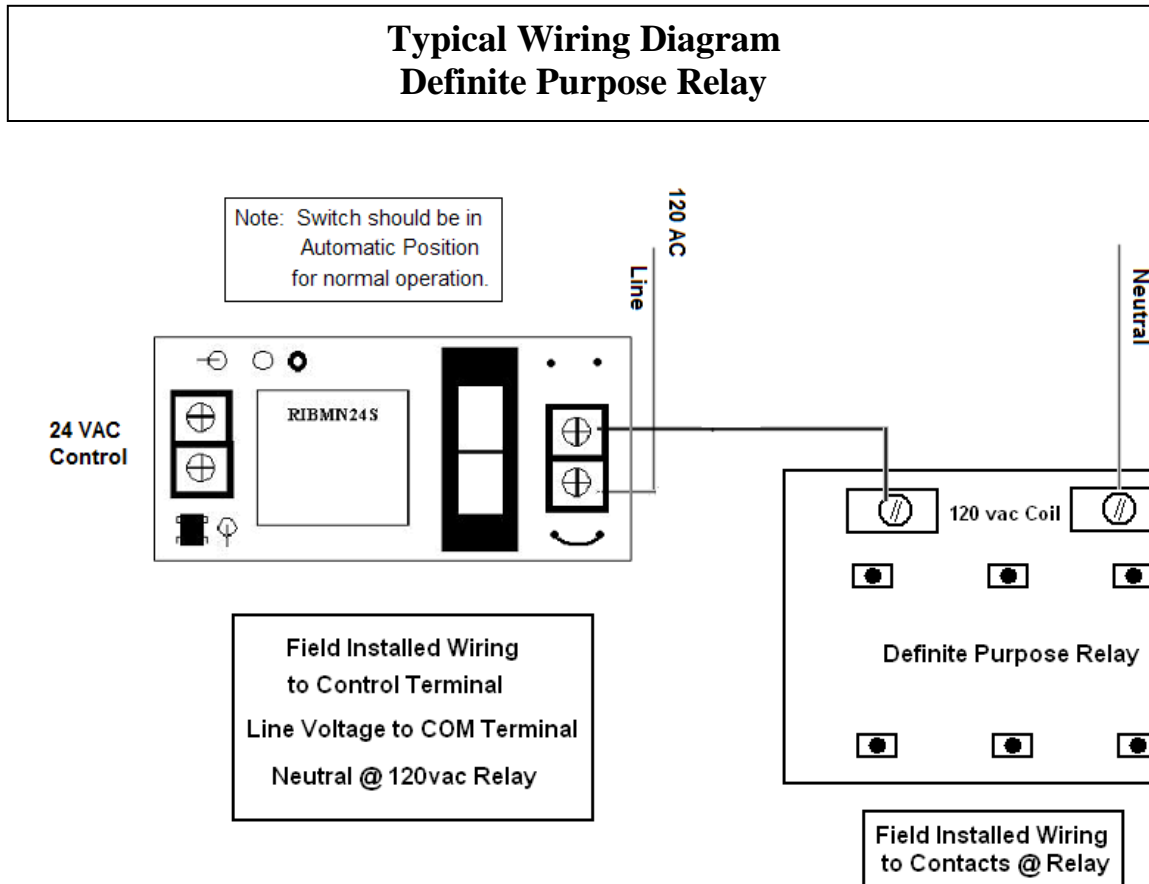

Definite Purpose Relays:

This E-Series Enclosure is provided Definite Purpose Relays to control devices such as Exhaust Fans or Range. This relay is controlled by a 24-vac signal from the Utility Controller.

Optional Sequences of Operation are: (Contact factory regarding these options.)

- Relays energizes with “EMS” ON input signal.
- Activating the key switch is required for first engagement.
- “EMS” OFF and/or panic state will de-energize relays.

Installing the Enclosure

CAUTION: Provided mounting hardware must be used.

There are two options for mounting the E-Series Enclosure: Flush Mounted and Surface Mounted.

Flush Mounted: Style 2

Prior to installation:

- The Enclosure mounts between two standard spaced wall studs within a minimum 6" wall cavity.
- If stud spacing is greater than that required for the mounting of the controller, add studs to insure a secured mounting.
- The studs should be facing to facilitate securing the enclosure.
- Predetermine wall finish so that the face lip of the enclosure aligns flush with the finished wall surface.

To install:

1. Using the self-starting screws (13), mount the flanges at each side and at the top and bottom of the enclosure.
2. Attach the enclosure to the wall studs with field-provided sheet metal screws per the drawing.
3. Level the enclosure.

Notes:

- When the Door Panel is mounted onto the controller, it should protrude beyond the wall surface about 1/4".
- Care should be taken at installation time to ensure that this occurs.
- A Flush Mounting Trim Flange is provided with each flush mounted unit. Separate installation instructions and hardware are included with this flange.
- It is the responsibility of the installer to verify finish wall

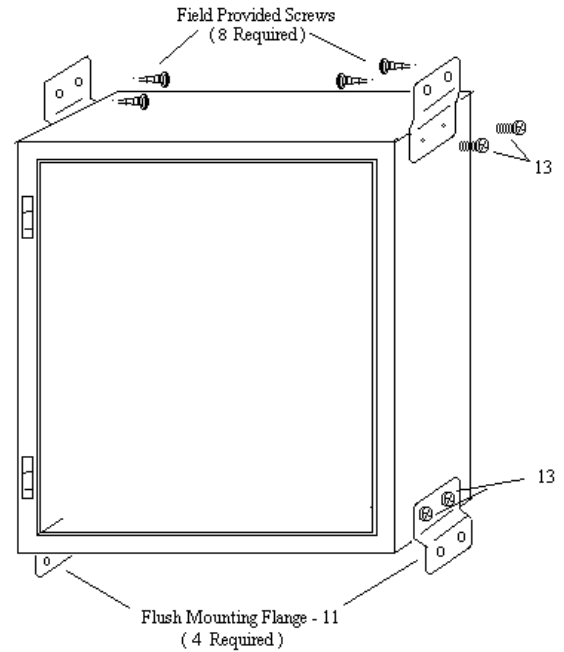

For best Flush Mounting results, recess face of enclosure's lip 1/4" behind wall finish

Flush Mount Style 2 Enclosures: Clearance around Enclosure:

Care should be taken to allow 1/2" clearance from wall framing and sheet-rock or other wall surface material around the outer surface of the unit to permit the trim to be properly installed.

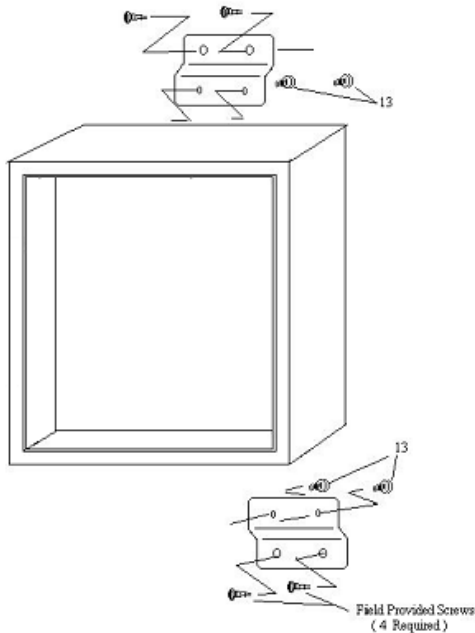

Surface Mounted: Style 1

Prior to installation:

- Wall finishes should be complete.
- The wall cavity must have sufficient backing or support to ensure a firm mounting of the enclosure to the wall surface.

To install: Where flanges are provided.

1. Secure the surface mount flanges to the back of the enclosure with the self-starting screws (13).
2. Use the field-provided screws to attach the enclosure by the flanges to the wall surface.
3. Level the enclosure.

Surface Mounted: Special Notations

Standard units are provided in a 16X12X4 enclosure with mounting hardware and screw latch removable front panel. The units are intended to be surface mounted.

Custom and units with excess of 12 pole contacts are provided in a 18X18x4 enclosure.

See page 7 – Installing Door Panel and Trim for instructions on Style 2 enclosures.

Installing the Door Panel: Series 1 & 4 only

To install the Door Panel on the Enclosure:

1. Position the door at 90° – 100° of enclosure.
2. Slide top hinge pin onto fixed hinge post at top of door.
3. Slide lower hinge pin toward lower spring hinge mechanism with hinge pin lever in retract position.
4. With lower hinge pin in position, turn hinge pin lever outward and down, then turn inward to the extended lock position.

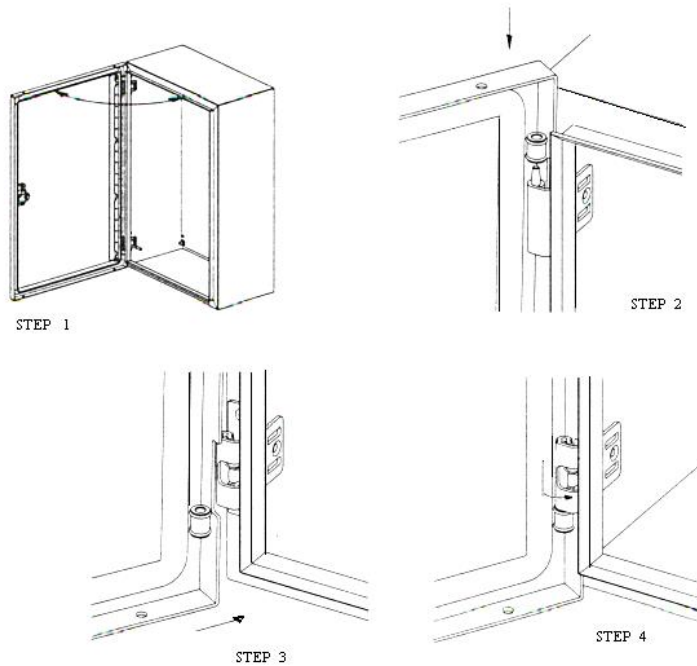

Installing the Flush Door Trim: Series 1 & 4 only

Prior to installing Door Trim, ensure that wall finishes are complete and that the door panel has been installed. Flush Trim adds 3 1/2" to both Height and Width Wall Surface dimensions.

To install the Flush Door Trim:

1. With the door in the open position, slide flush door trim over enclosure.
2. Align holes on enclosure with upper and lower holes in door trim.
3. Insert four (4) 8-32 (provided) screws through enclosure panel and tighten into door trim.

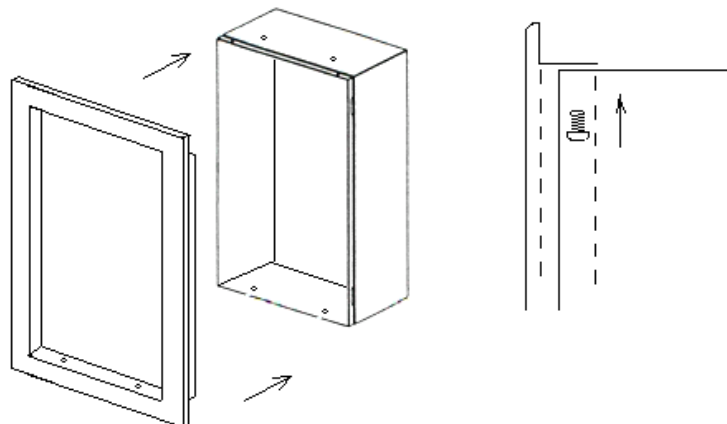



ISIMET/MAPA, LLC

**103 W. CJ Wise Parkway
PO Box 129 (Mailing)
Naples, TX 75568
Phone (866) 897-0737
Fax (903) 897-0740**

www.ISIMET.com

**Innovative Systems
Integrating
Mechanical and Electrical
Technology**